



Alternative Maritime Power Project

# TERASAKI AMP SYSTEM

(Cold Ironing project)



- 24 April 2006 -



# MADE IN TERASAKI !

**Medium Voltage  
Switchboard  
HS21**



**NEW!!**



**Low Voltage  
Switchboard  
MS22**

**NEW!!**



**Group  
Starter  
Panel  
GS22**

**Integrated Monitoring &  
Control System  
WE22**

**NEW!!**

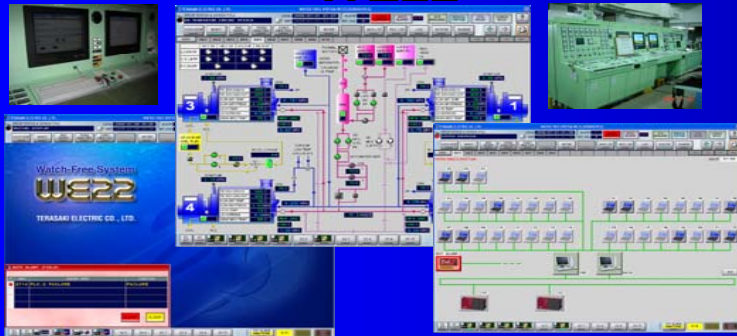

**ACB & MCCB**

**TEM POWER 2**

**TEM BREAK 2**



**NEW!!**





# *TERASAKI AMP SYSTEM*

## Ship-Based Power Supply System



Berth 216 (NYK – High voltage power supply)

Berth 231 (Evergreen – Low voltage power supply)

*Our Concept*  
*Easy Connection!*  
*Easy Operation!*



**Berth 216 NYK**



**Berth 231 Evergreen**





# *TERASAKI AMP SYSTEM*



## Ship-Based Power Supply System

# Berth 216 (NYK – High Voltage power supply)

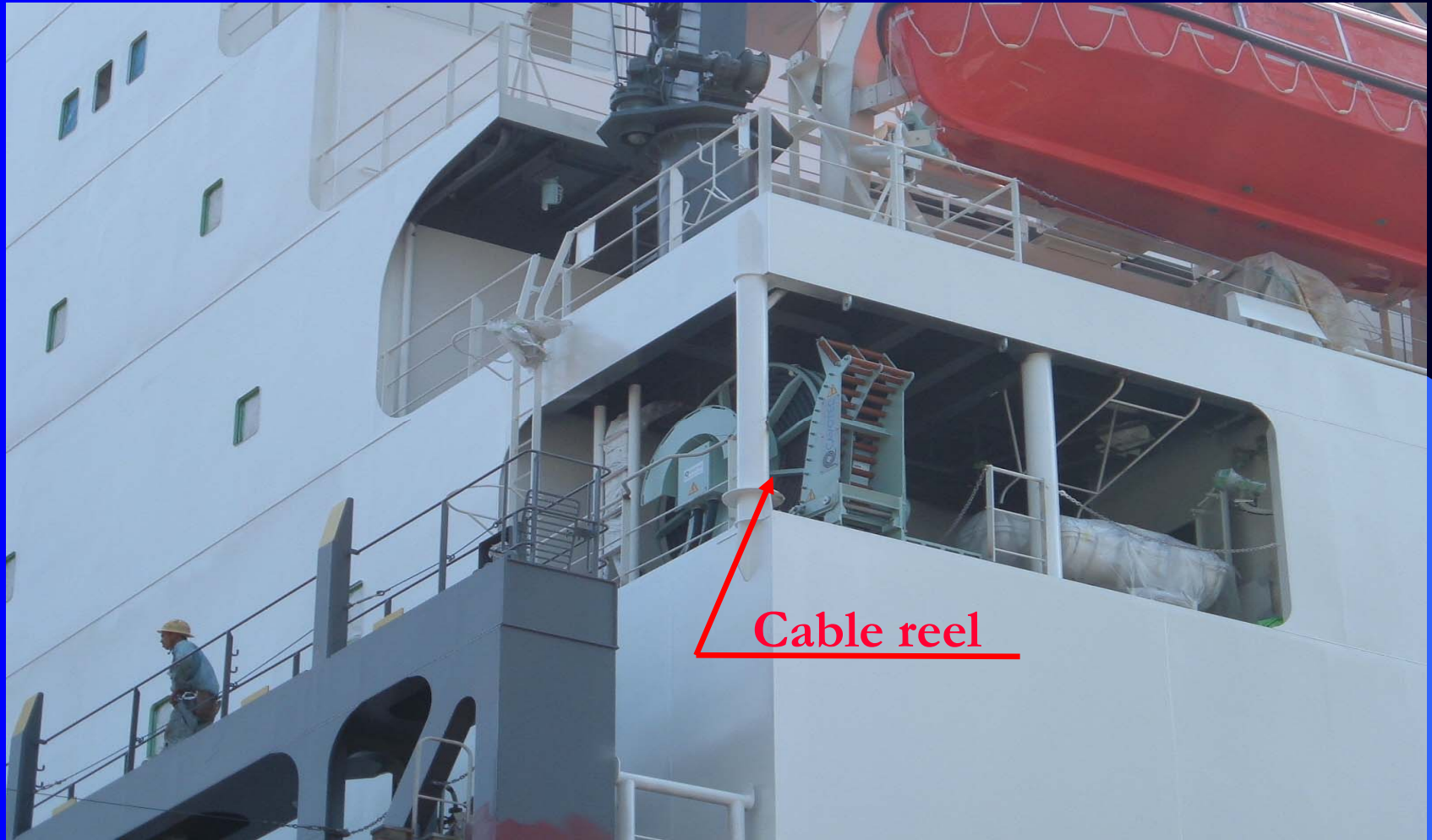

# Berth 216 (NYK – High Voltage power supply)

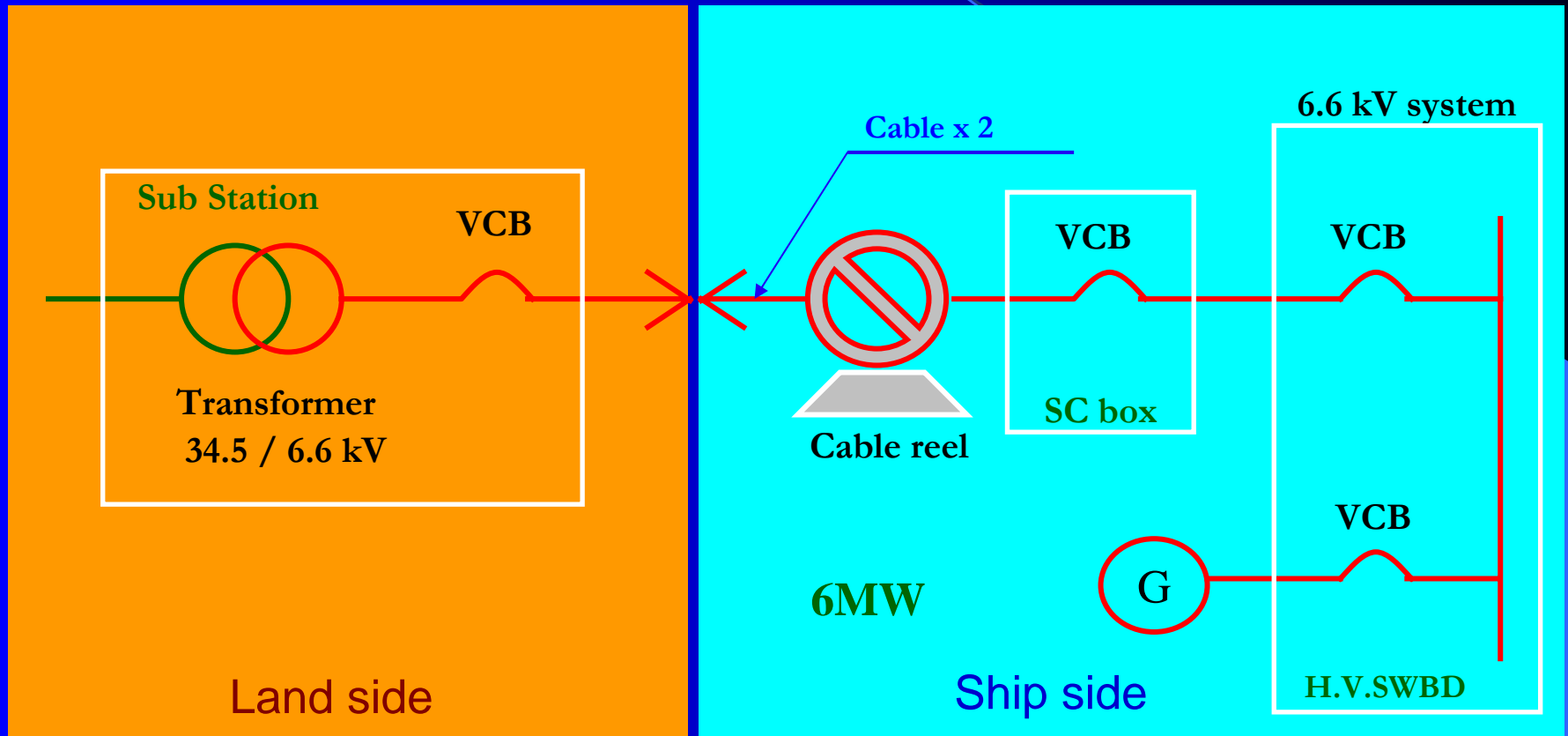

# Berth 216 (NYK – High Voltage power supply)

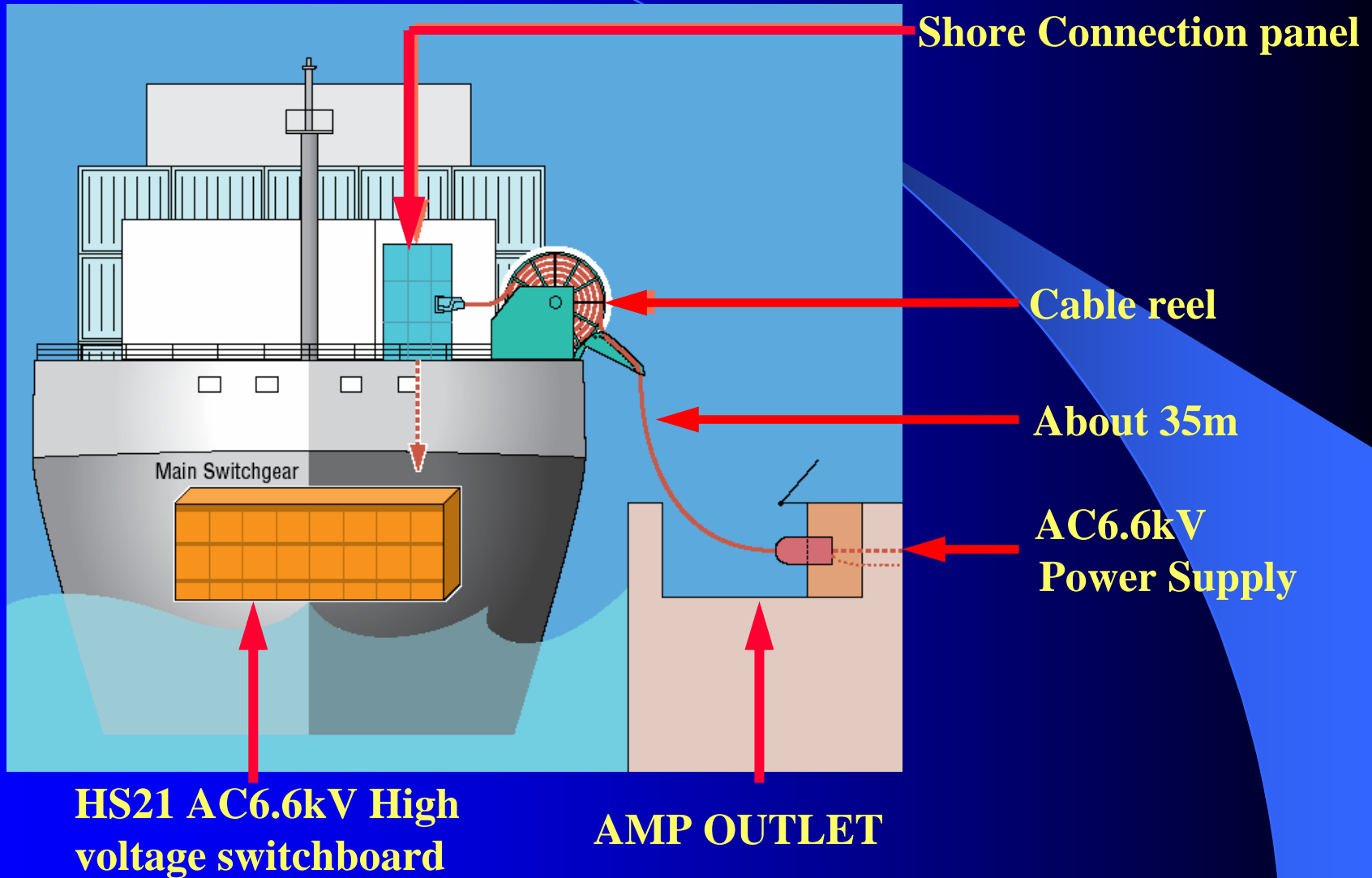

# Berth 216 (NYK – High Voltage power supply)

Cable reel



Cable reel



Shore connection panel on ship



Cable control box



# Berth 216 (NYK – High Voltage power supply)

**AMP Outlet**



**AMP Outlet**



High voltage cable



Telescopic lifting arm



Easy Connection!  
2 cables only!

High voltage cable

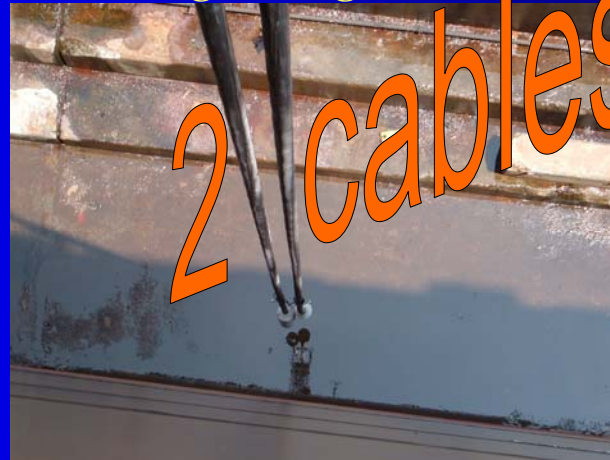

# Berth 231 (Evergreen – Low Voltage power supply)

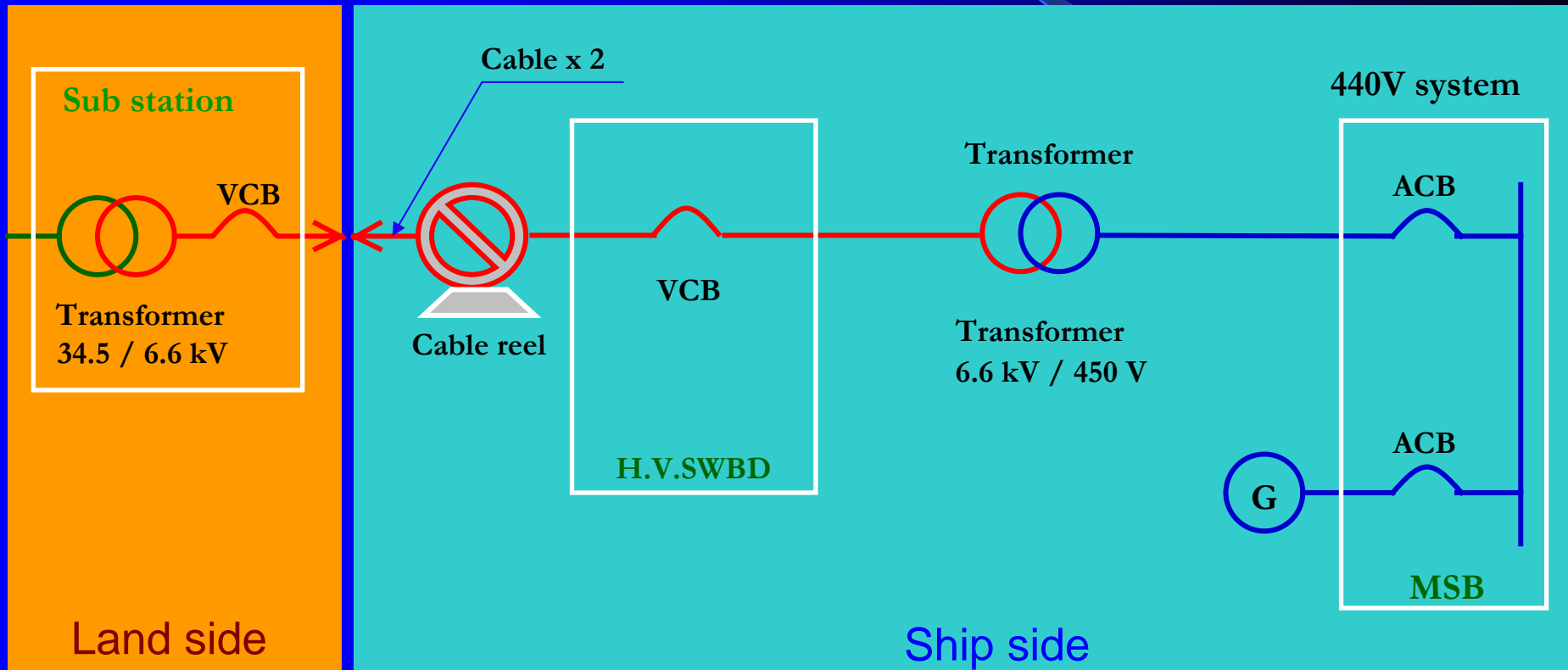

# *AMP MANAGEMENT CONSOLE*



*Switching of the power supply with the ship and the shore is one touch operation !*

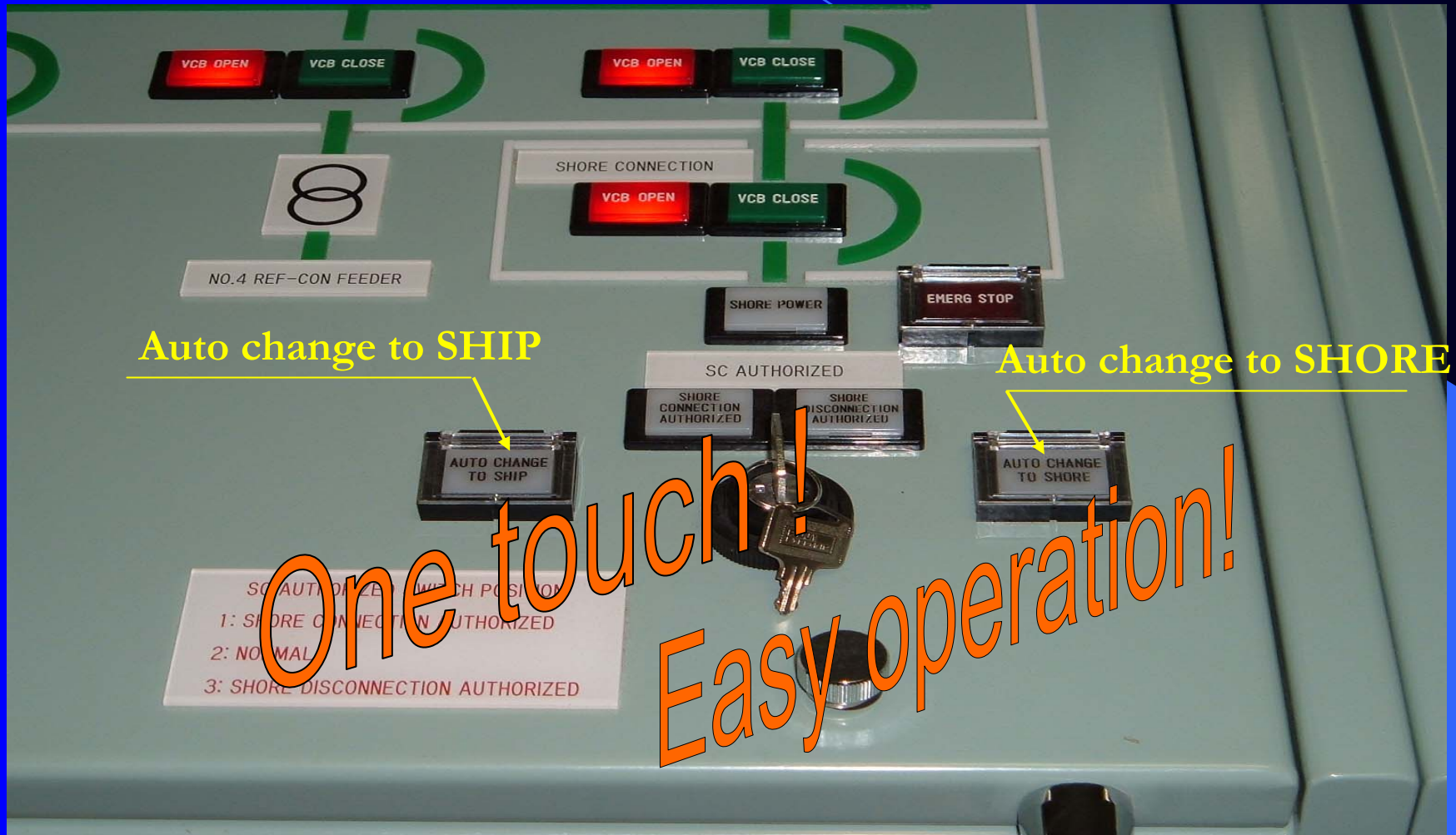

# Safety system between shore and ship

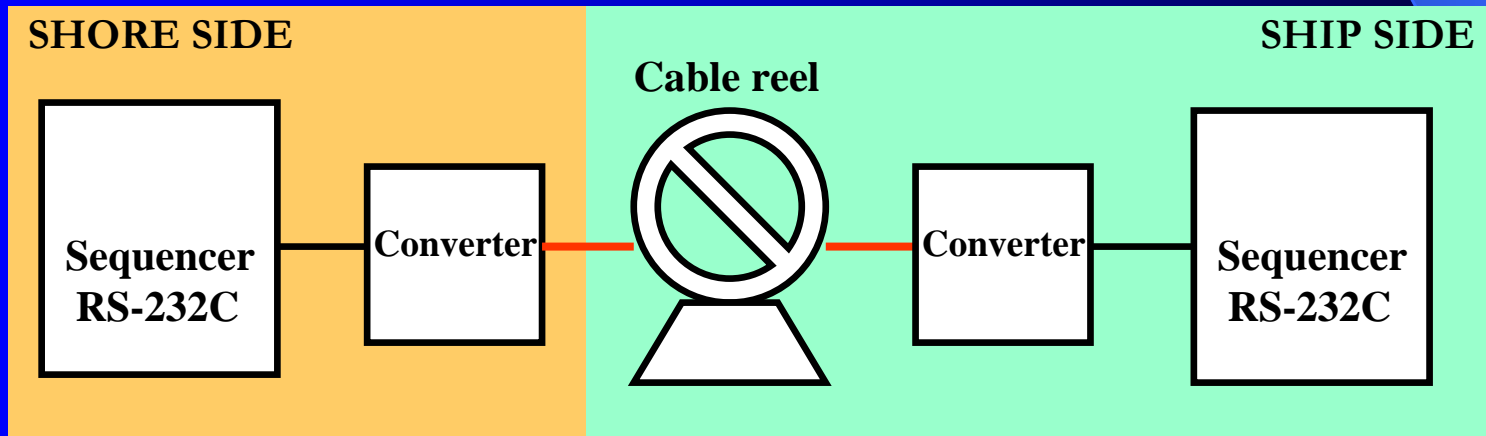
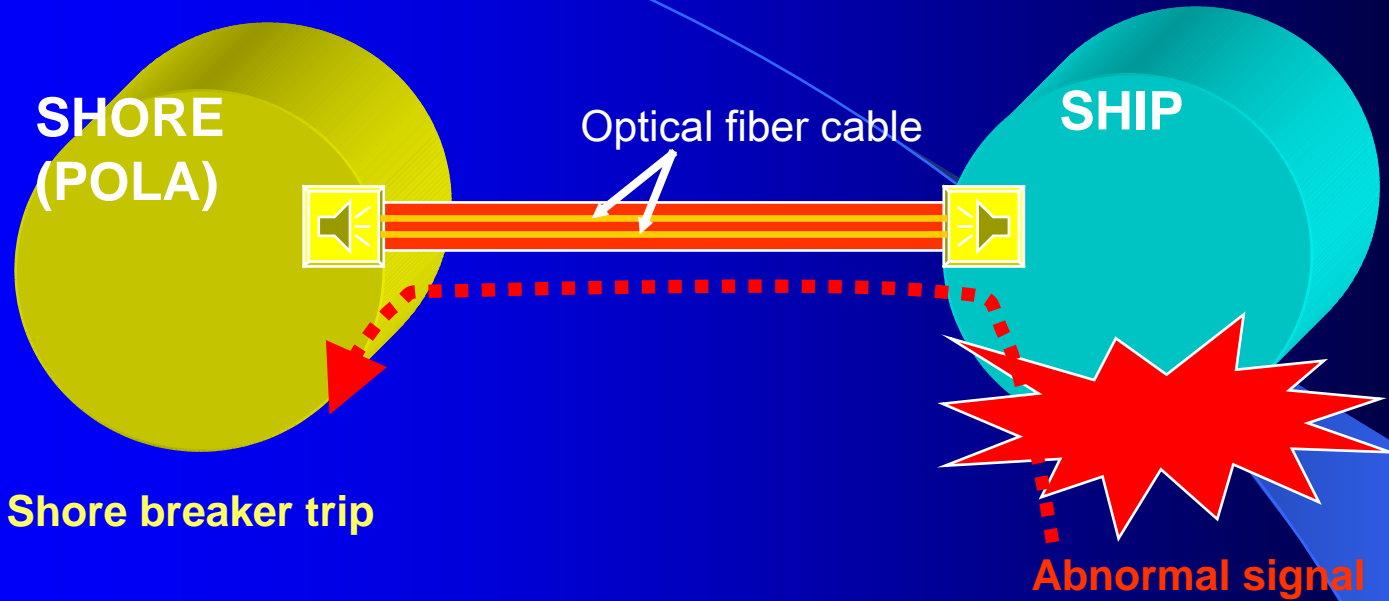

# *The detection system of connector off*

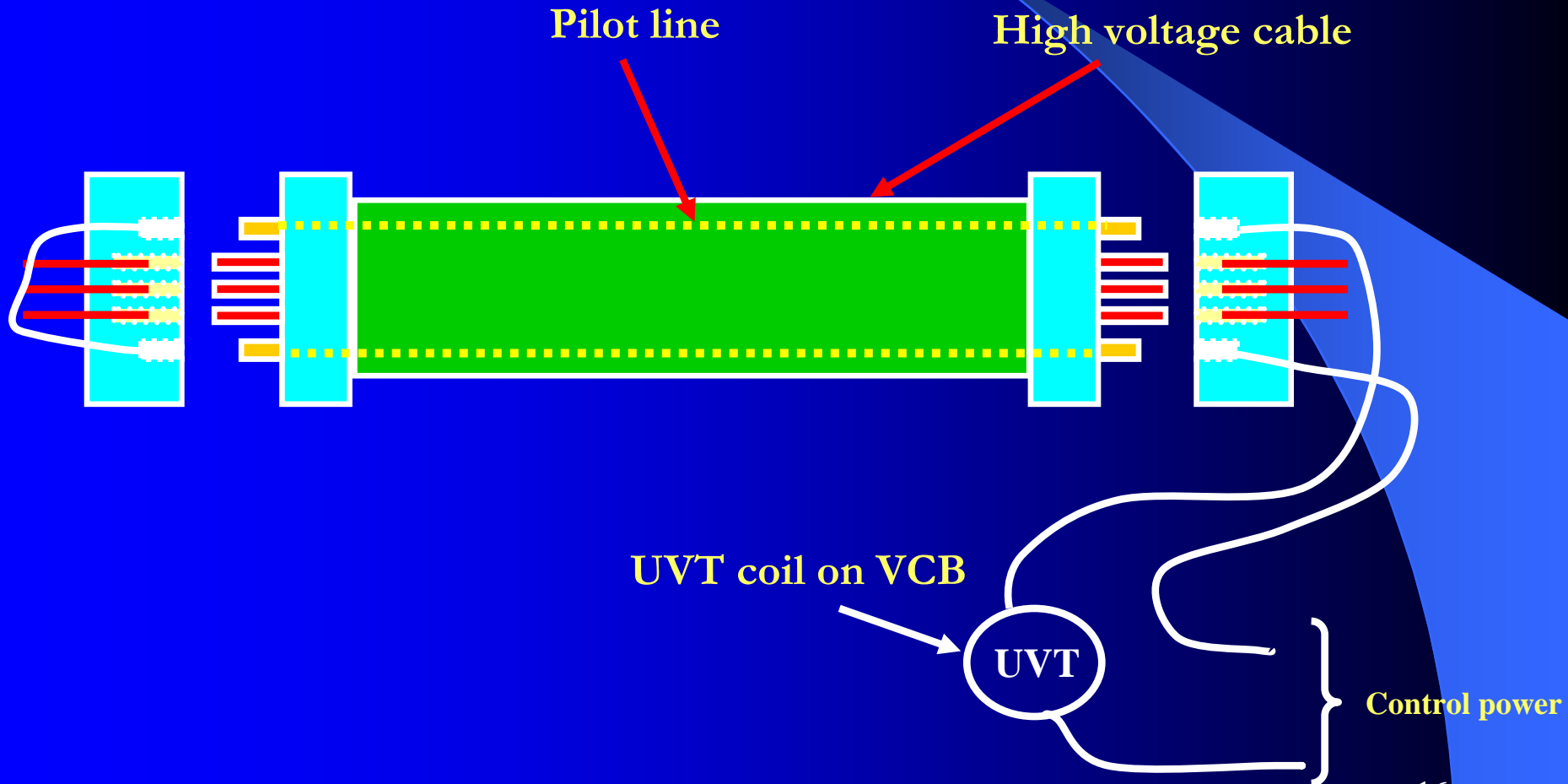

# Mobile Container System

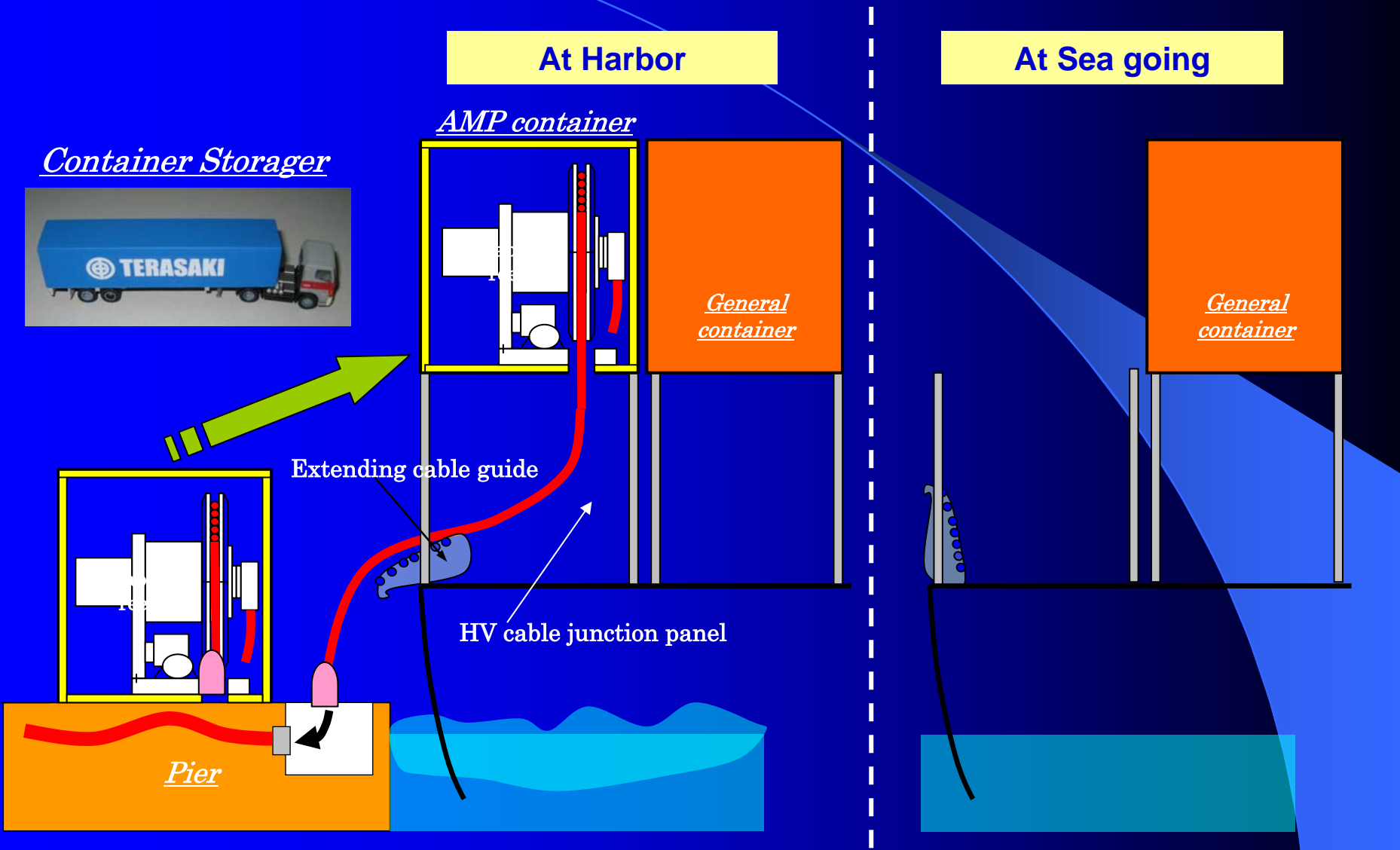

## *TERASAKI Schedule for AMP system*

No.	SHIP OWNER	SHIP BUILDER	SHIP No.	DELIVERY	RULE	TYPE OF VESSEL	PRODUCTS
1	NYK	IHIMU (Kure)	S.no.3169	2004-05	NK	Container Vessel	6,600V to 6,600V 6,000KW
2	EVERGREEN	MHI (Kobe)	S.No.1265	2004-11	LRS	Container Vessel	6,600V to 440V 6,000KW
3	EVERGREEN	MHI (Kobe)	S.No.1266	2005-03	LRS	Container Vessel	6,600V to 440V 6,000KW
4	EVERGREEN	MHI (Kobe)	S.No.1267	2005-06	LRS	Container Vessel	6,600V to 440V 6,000KW
5	EVERGREEN	MHI (Kobe)	S.No.1268	2005-10	LRS	Container Vessel	6,600V to 440V 6,000KW
6	EVERGREEN	MHI (Kobe)	S.No.1269	2006-01	ABS	Container Vessel	6,600V to 440V 6,000KW
7	EVERGREEN	MHI (Kobe)	S.No.1271	2006-05	ABS	Container Vessel	6,600V to 440V 6,000KW
8	EVERGREEN	MHI (Kobe)	S.No.1272	2006-08	ABS	Container Vessel	6,600V to 440V 6,000KW
9	EVERGREEN	MHI (Kobe)	S.No.1273	2006-11	ABS	Container Vessel	6,600V to 440V 6,000KW
10	EVERGREEN	MHI (Kobe)	S.No.1274	2007-02	ABS	Container Vessel	6,600V to 440V 6,000KW
11	EVERGREEN	MHI (Kobe)	S.No.1275	2007-05	ABS	Container Vessel	6,600V to 440V 6,000KW

# Global Service Network

Wherever your vessel is, we have a service team within reach

Main Service & Spares Center

## TERATEC LTD.

7-9-10 Hannancho  
Abeno-ku, Osaka, 545-0021, JAPAN  
Tel : +81 6 6693 6974  
Fax : +81 6 6693 7116  
E-Mail parts : elparts@teratec.co.jp  
E-Mail maintenance : shipeng@teratec.co.jp  
Web site : www.teratec.co.jp

## Covering Korea

**DAEWOO MARINE IND.CO., LTD.**  
756-8, Yochon-Dong, Nam-Ku  
Ulsan, Korea  
Tel : +82 52 269 5996  
Fax : +82 52 269 5998  
E-Mail : ulsan@dmico.net  
Web site : www.dmwarinid.com

## Covering China

**TERASAKI ELECTRIC (CHINA) LTD.**  
72 Pacific Industrial Park  
Xintang Zengcheng, Guangzhou  
511340, China  
Tel : +86 20 8270 8556  
Fax : +86 20 8270 8586  
E-Mail : terasaki@public.guangzhou.gd.cn

## Covering South East Asia

**TERASAKI ELECTRIC CO.,(F.E.) PTE. LTD.**  
23 Bukit Batok Street 22,  
Singapore 659590  
Tel : +65 6561 1166  
Fax : +65 6561 2166  
E-Mail : tele@terasaki.com.sg  
Web site : www.terasaki.com.sg

## Covering Oceania

**NOVAMARINE INSTRUMENTS PTY. LTD.**  
30 Downia Street, Newcastle  
2293 Australia  
Tel : +61 2 4969 4477  
Fax : +61 2 4962 1210  
E-Mail : service@novamarine.com.au  
Web site : www.novamarine.com.au

## Terasaki Representative

**TERASAKI ELECTRIC GROUP  
SHANGHAI REPRESENTATIVE OFFICE**  
Room No.1405-6  
Tomson Commercial Building  
710 Dong Fang Road, Pudong,  
Shanghai 200122, China  
Tel: +86 21 58201611  
Fax: +86 21 58201621  
E-Mail: terasaki@vip.163.com

## Covering Europe, Africa

**DIRECT RESPONSE**  
Terasaki (Europe) Ltd.  
80 Beardmore Way, Clydebank  
Scotland, G81 4HT, UK  
Tel : +44 141 941 1940  
Fax : +44 141 952 9246  
E-Mail : directresponse@terasaki.co.uk  
Web site : www.terasaki.com

## Covering The Netherlands

**GTI MARINE & OFFSHORE B.V.**  
Sluisdijk 37-3087 AD Rotterdam  
Harbour No. 2110  
Postbox 59029-3006PARotterdam, The Netherlands  
Tel : +31 10 42 95 200  
Fax : +31 10 42 95 005  
E-Mail : info-marine-offshore@gti-group.com  
Web site : www.gti-group.com

## Covering North & Central America

**AMERICAN TERATEC INC.**  
209 Industrial Parkway  
Northvale  
New Jersey, 07647, USA  
Tel : +1 201 767 8080  
Fax : +1 201 768 2570  
E-Mail : ati@teratecusa.com  
Web site : www.teratecusa.com

## Covering Middle East

**TERASAKI (MIDDLE EAST)**  
Lob 6, Office 13 Jebel Ali Free Zone  
P.O.Box 261080  
Dubai, U.A.E.  
Tel : +971 4 881 2242  
Fax : +971 4 881 2243  
E-Mail : terasaki@emiratee.net.ae

## Covering South America

**TERASAKI DO BRASIL LTDA.**  
Rua Cokdovil 259 - Parada De Lucas  
Rio De Janeiro RJ Brasil  
Tel : +55 21 3301 8898  
Fax : +55 21 3301 9861  
E-Mail : terasaki@terasaki.com.br  
Web site : www.terasaki.com.br

## Terasaki Representative

**TERASAKI ELECTRIC CO.,LTD  
HUMBURG OFFICE**  
Anderheitsallee 4c  
22175 Hamburg, Germany  
Tel: +49 40 55 611 911  
Fax: +49 40 55 611 912  
E-Mail : dan.graniosanu@terasaki.de

*Terasaki Global Service Network  
operates  
24 hours a day!*



Operation downtime and incidents which threaten power supply at any time are costly and may endanger lives. That's the why Terasaki Global Service Network(GSN) operates 24 hours a day.

### TERASAKI CUSTOMER SUPPORT

- Ship Owners
- Ship Operators
- Ship Managers
- Marine Engineers
- Maintenance Contractors

### TERASAKI TECHNICAL SUPPORT

- Preventative Maintenance
- Inspection, Testing & Surveys
- Service, Rectification & Repairs
- Upgrade & Modification
- Spare Parts Supply & Advice
- Workshop Overhaul
- Retrofit

### TERASAKI EQUIPMENT SUPPORT

- Main Switchboards
- Generator Automatic Control Systems
- Monitoring Systems
- Cargo Control Systems
- Group Starter Panels
- Air Circuit Breakers
- Moulded Case Circuit Breakers



**TERASAKI**